

Article number: 604132028050

Description: Taper bored timing belt pulley  
HTD 28 8M 50 TL 1210

## Measures

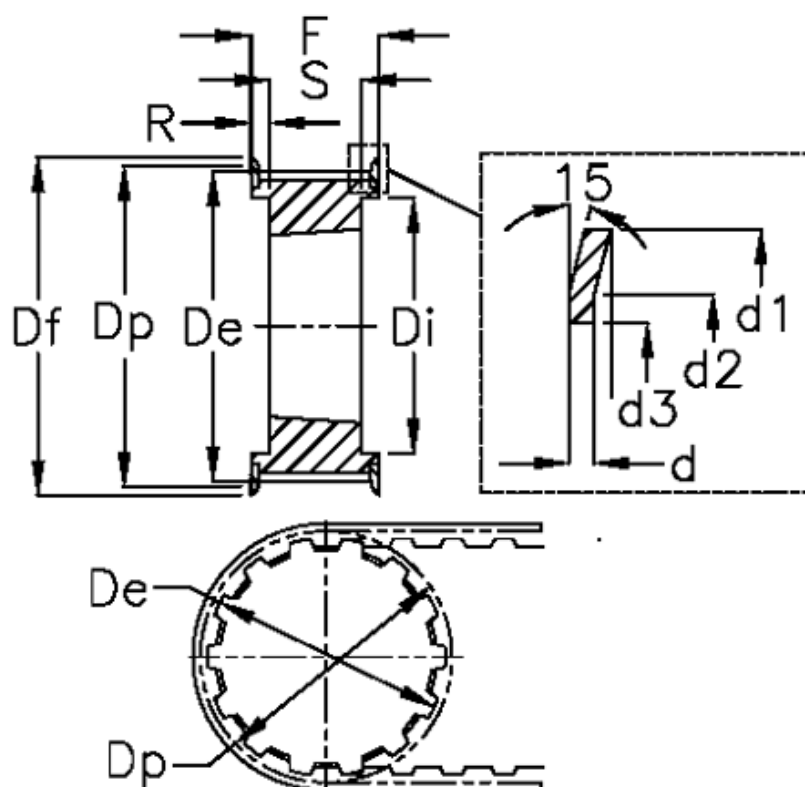

d = 1.5	F = 60	Weight = 0.6
d1 = 75	Flange type = F27	Width = 50
d2 = 68.5	For bushing = 1210	
d3 = 60	Max bore = 32	
De = 70.08	r = 17.5	
Df = 75	S = 25	
Di = 50	Tooth number = 28	
Dp = 71.3	Type = 8M	